

Capacity Building workshop
**EE improvements in
compressed air and cooling
water systems**

7th March 2018 at Belgaum

Under the project
Capacity Building of Local Service Providers
(LSPs)

Supported by
GEF-UNIDO-BEE Project
Promoting Energy Efficiency and Renewable Energy in
selected MSME clusters in India



Table of contents

WORKSHOP SUMMARY.....	1
Overview of workshop.....	1
Summary of points discussed in the meeting.....	1
Feedback forms.....	1
Suggestions by participants.....	2
Learning's by participants.....	2
ANNEXURE 1: AGENDA OF THE PROGRAM.....	3
ANNEXURE 2: LIST OF PARTICIPANTS.....	5
ANNEXURE 3: SELECTED PHOTOGRAPHS OF THE EVENT.....	11
ANNEXURE 4: SAMPLE FEEDBACK FORMS.....	13
ANNEXURE 5: COPY OF PRESENTATIONS.....	19

Workshop summary

Overview of workshop

Capacity Building workshop of Local Service Providers (LSPs) on Energy efficiency improvements in compressed air systems and cooling water systems was organized by TERI on 7th March 2018, Wednesday in association with Belgaum Foundry Cluster (BFC) under GEF-UNIDO project. Total 34 participants were present during the workshop and for the industry visit, which was organized after the workshop. Agenda of the workshop and list of participants are attached in the annexure 1 and annexure 2 respectively.

Summary of points discussed in the meeting

Mr. Sadanand Humbarwadi, UNIDO welcomed the participants and thanked all the participants. He gave short introduction about the background and experience of the TERI experts. He briefed about the topics which were going to be presented during workshop. He mentioned that, after induction furnace, air compressor and cooling water systems consumes most of the power in a typical foundry and most of the power and energy losses are observed in these systems. He encouraged participants to take advantage of TERI experts during workshop, which are made available by UNIDO for capacity building of LSPs.

Mr. Vivek Sharma, TERI, gave descriptive presentation on cooling water systems in induction furnace and how the losses occur in the pumps. He shared his experiences in Rajkot foundry cluster and gave examples of successful case studies in pumping system. He talked about the maintenance check points for cooling water circuit. He also introduced new technologies available in pumps and cooling towers and encouraged participants to adopt these technologies to achieve significant energy savings.

Mr. Nilesh Shedge, TERI, gave detailed presentation on air compressor systems and shared actual case studies of implementation of new technologies in air compressors done by TERI in foundries. He talked about the different components of compressed air systems like dryers, air piping, receiver tanks and their significance in the overall system efficiency. He highlighted that air compressors are the most inefficient systems and proper sizing of the machines along with regular checks on air leakages in the plants are important points to avoid losses.

After the lunch, plant tour through the M/s Abhishek Alloys Pvt Ltd (Unit-1) was arranged, so that on site discussion about the presented systems can be done with the participants to enhance the learning experience. After the plant visit a short tour to Sand Reclamation Facility operated by BFC in Belgaum was carried out. Workshop went in a very interactive way, participants asked many questions and TERI team as well as LSPs present satisfied those queries. He also thanked all the participants for taking a day for the workshop. Selected photos of the workshop and visit are attached in the annexure 3.

Feedback forms

Based on the analysis of the feedback forms received from the participants, it is observed that workshop was well received by the participants and 100% participants were satisfied with Q&A session and 90% of the participants were satisfied with training module provided to them. Around 55% of participants rated training schedule and industrial site visit as "Excellent". More than 50% participants have rated overall program as "Excellent" while

rest of them have rated it as “Good”. About 50% of participants were satisfied with arrangements made and have rated industrial visit as “Good”. Few sample feedback forms are attached in the annexure 4.

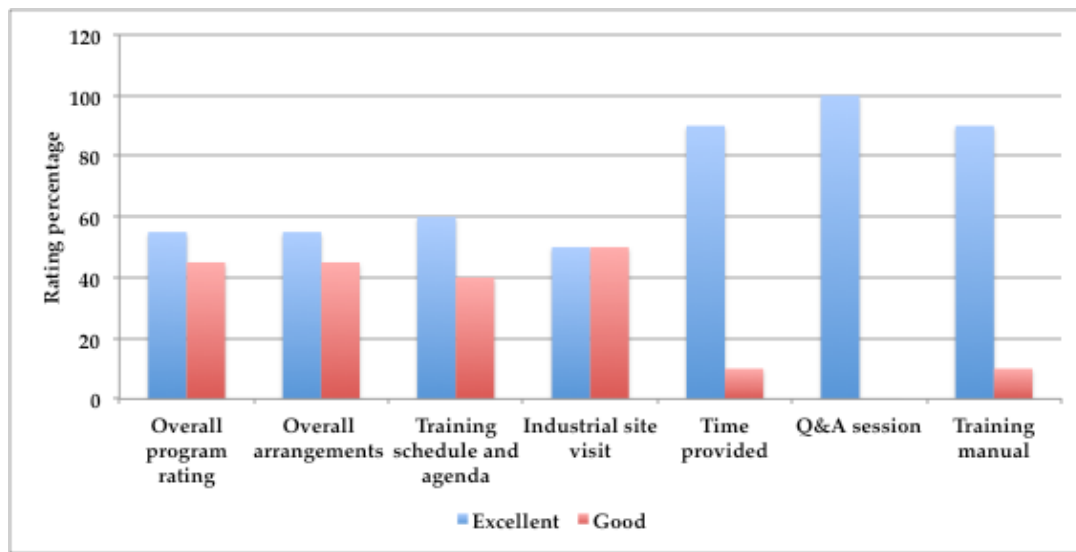

Analysis of feedback forms

Suggestions by participants

Some participants have made suggestions as follows;

- 1) Information on energy monitoring system
- 2) Full day separate workshop for maintenance people on air compressor and water systems should be arranged

Learning's by participants

Some of the topics learned by the participants and mentioned by them are listed below;

- 1) Sizing of air receiver
- 2) Air compressor location requirements
- 3) Air pipe selection
- 4) Latest technologies in air compressor and pumps
- 5) Importance of air dryer and its sizing
- 6) Significance and losses occurring due to air leakages
- 7) Air pressure reduction
- 8) Energy monitoring is equally important

Annexures

Annexure 1: Agenda of the program



Capacity building workshop
Energy efficiency improvements in compressed air and cooling water systems

Wednesday, 7 March 2018

Training Hall, Belgaum Foundry Cluster

Under the project:

Capacity Building of Local Service Providers (LSPs)

Supported by:

GEF-UNIDO-BEE Project

Promoting Energy Efficiency and Renewable Energy in selected MSME clusters in India

Agenda

10:00 – 10:30	Registration
10:30 – 10:40	Welcome Address Mr Ram Bhandare, Chairman, Belgaum Foundry Cluster
10:40 – 10:50	GEF-UNIDO-BEE project and initiatives in Belgaum cluster Mr Sadanand Humbarwadi, UNIDO Cluster Leader - Belgaum
10:50 – 11:50	Energy efficiency improvement opportunities in induction furnace cooling water system Mr Vivek Sharma, TERI
11:50 – 12:50	Energy efficiency improvement opportunities in compressed air system Mr Nilesh Shedge, TERI
12.45 – 13:00	Q&A
13:00 – 14:00	Lunch
14:00 – 16:00	Site Visit / On-site training Visit to a foundry unit
16.00 – 16:30	Feedback from participants
16:30 – 16:45	Vote of thanks

Organized by









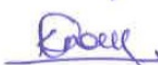

Annexure 2: List of participants

S. No.	Name	Organization	Mobile No	Email ID
1.	S. R. Suryavanshi	M/s Aqua Alloys (P) Ltd.	9243222920	projects@aqualloys.com
2.	R. G. Kumbhar		9243207089	
3.	Gajanan K.	Gokul Ferrocast Pvt. Ltd	9731891400	maintenance@gokulferrocast.com
4.	Vinay A.D.	M/s Victor Enterprises	7760435266	Vinay.dicholkar@outlook.com
5.	Narayan B.	Gokul Ferrocat Pvt. Ltd.	8884029700	Narayanb39@yahoo.com
6.	Manjith Savadatti	Big castings Pvt Ltd.	9513395172	Manjith.savadatti@bigcastings.com
7.	Ajit A Chougala	Big castings Pvt. Ltd.	9964763950	Ajit.chougala@bigcastings.com
8.	S. P. Manjrekar	AAPL	9844880749	sheelmanjrekar@yahoo.com
9.	Krishan Naik	Kudale Iron Works	88615527845	kudaleiw@gmail.com
10.	Shiridhar Pal	AKP Ferrcast	7676325451	
11.	Sameer	Pheonix	9448480724	
12.	Samarth	Pheonix	8867383292	
13.	Ravi K	Amith Fero cast	8880875101	
14.	Rajesh G Nesikar	Shanti Iron & Steel	9141563668	
15.	Mahadev R Badiges	Shanti Iron & Steel	8747031395	Mahadevbadiges35@gmail.com
16.	D. P. Yallunkar	AKP Foundries	9448451855	
17.	Riyaz Subkhan	Unitech Electical Centre	9480398230	shabbirsubhkhanusec@gmail.com
18.	P Nagaraj	BFPL Unit II	9480839971	
19.	Shivaji Gavade	Technosystems	9036828075	technosysbm@bsnl.in
20.	Savant N.	Ashok Iron		
21.	Sanjay	REC foundry	9731794637	foundry@recenergy.com
22.	Rameshwar J	REC foundry	9731794637	foundry@recenergy.com
23.	Somkumar D Pati	Belgaum Faoundry Cluster	9742164712	bfcgubproject@gmail.com
24.	Bhushan G. M.	Shree Enterprises	9241695987	darshanbgm@yahoo.co.in
25.	Saterin N. G.	B.F.C.	9739389949	
26.	Sachin Patil	Industrial		
27.	Amit Sathaye	Prakash Sales Agencies Belgaum	9449053626	
28.	Ramakrishna Bhat	B.F.C.	8277609577	
29.	S. N. Dhamneker	Ashok Iran Plant I		
30.	Vivek Sharma	TERI	9850366248	
31.	N . M. Khatib	BFC II	9945117867	
32.	Nilesh Shedge	TERI	9978601047	
33.	Sadanand D. H.	BFC	9448272499	







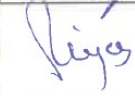

Capacity building workshop
Energy efficiency improvements in compressed air and cooling water systems







07 March 2018, Training Hall, Belgaum Foundry Cluster

S. No	Name	Organization	Mobile No	Email ID	Signature
1.	S. R. Suryavanshi	M/S- Aqua Alloys (P) Ltd.	9243222920	projects@aqualloys.com	
2.	R. G. Kumbhar	—————	9243207089	—————	
3.	GAJANAN. K.	GOKUL FERROCAST Pvt Ltd.	9731891400	maintenance@gokulferrocast.com	
4.	Vinay A. D	M/S Victor Enterprises	7760435266	vinay.dichodkar@outlook.com	
5.	Narayan B.	Gokul Ferrocast Pvt. Ltd.	8884029700	Maintenance Dept narayn b 29@yahoo.in	
6.	Manjiv K. Saradatti	Big castings (P) LTD Pune	9513395172	Manjiv.k.saradatti@bigcastings.com	
7.	Ajit A. Chougale	Big Castings Pvt Ltd.	9964763950	ajit.chougale@bigcastings.com	

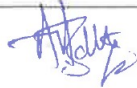
S. No	Name	Organization	Mobile No	Email ID	Signature
8.	S.P. Mangulkar	AAPL	9844880749	snceel mangulkar@yahoo.com	
9.	Krishna Naik	Kudale Iron Works	8861527845	Kudaleiw@gmail.com	
10.	Shruthas Pat.	AKP FERROCAST	7070895451		
11.	Sameer	Phoenix	9448480724	phoenix_sgm@hotmail.com	
12.	Samant	Phoenix	886738292		
13.	Ravik K	Ameth Ferro cast	8880378101	Ravikallionani@gmail.com	
14.	Rajesh. G. Naliker	Shanki Iron & Steel	9141563668		
15.	Mahadev R. Badiger	Shanki Iron & steel	8747031395	Mahadev badiger@35@gmail.com	
16.	D. P. Yallurkar	AKP Foundries	9448451875	akpfdy@akpfoundries	
17.	Riyaz. Subkhan	unitech electrical works	9480398230	shabbirsubkhan@gmail.com	

Capacity Building Workshop of Local Service Providers (LSPs) on EE improvements in compressed air and cooling water systems

S. No	Name	Organization	Mobile No	Email ID	Signature
18.	P. Naqaraj	BFPL Unit II	9480839971 9480 9448497	—	
19.	Shivaji Gavade	Technosystems	9036828075	tecnosysbm@bsnl.in	
20.	शिवजी गिरीशमोह	आरिशी फ		Ashok Iron	शिवजी गिरीशमोह
21.	Sanjay Z	REC foundry	9731794637	foundry@recengej.com	
22.	Rameshwar J	"	9731794651	"	
23.	Rameshwar J	—	—	—	
24.	Sankumar D. Patil	Bilgaum foundry, churki	9742164712	btcgubprojeeel@gmail.com	
25.	Blushan G M	Shree Enterprises	9241695987	dashanbjm@yahoo.co.in	
26.	Sateerina, Cunnw	B.F.C	9989389149	—	
27.	Seelva Patil	Industham	9372852322	—	

S. No	Name	Organization	Mobile No	Email ID	Signature
28.	Amit Sathye	Prakash Sales Agencies, Belgann	9449053626	—	
29.	Ramakrishna Bhat	B.F.C.	8277609577	—	
30.	S. N. Dhanneker	Ashok Iron plant, EI	—	—	
31.	Vivek Sharma	TERI	9850366248		
32.	Nilesh Shedge	TERI	9978601047		
33.	N. M. Khatib	BFC - II.	9945119867	—	
34.	Sadomand D. H.	BFC.	9448272499		
35.					
36.					
37.					

Annexure 3: Selected photographs of the event



Annexure 4: Sample feedback forms

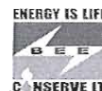

Capacity building workshop

Energy efficiency improvements in compressed air and cooling water systems

Wednesday, 07 March 2018

Training Hall, Belgaum Foundry Cluster

Supported by:

GEF-UNIDO-BEE Project

Promoting Energy Efficiency and Renewable Energy in selected MSME clusters in India

Evaluation Sheet for Participants

Feedback Form for Participants			
Parameter	Feedback		
	Excellent	Good	Average
How would you rate the overall programme?	✓		
How would you rate overall arrangements?	✓		
How was the training schedule and agenda?	✓		
How was the industrial site visit?	✓		
Do you think that adequate time was provided for each topic?	Yes [✓]	No []	
Do you think that satisfactory answers were given to your questions during the training programme?	Yes [✓]	No []	
Do you think that the background training manual is informative and useful enough?	Yes [✓]	No []	
Do you think that the discussion on EE/RE will help you in your work?	Yes [✓]	No []	
Suggestions & Recommendations for improvement:			
Name two learning, which from this programme you will be able to implement in your plant?			
* For air Comp. receiver tank volume increase			
* Air leakage arresting step by step + useful aluminium plate clamping + leak bending			
Signature:			
Name of participant: Swapnil P. Manjekar			
Organization: AAPI			
Mobile No: 9844650749			
Email ID: Snel.manjekar@yahoo.com			

Organized by





Capacity building workshop

Energy efficiency improvements in compressed air and cooling water systems

Wednesday, 07 March 2018

Training Hall, Belgaum Foundry Cluster

Supported by:

GEF-UNIDO-BEE Project

Promoting Energy Efficiency and Renewable Energy in selected MSME clusters in India

Evaluation Sheet for Participants

Feedback Form for Participants			
Parameter	Feedback		
	Excellent	Good	Average
How would you rate the overall programme?	<input checked="" type="checkbox"/>		
How would you rate overall arrangements?	<input checked="" type="checkbox"/>		
How was the training schedule and agenda?	<input checked="" type="checkbox"/>		
How was the industrial site visit?	<input checked="" type="checkbox"/>		
Do you think that adequate time was provided for each topic?	Yes [<input checked="" type="checkbox"/>]	No [<input type="checkbox"/>]	
Do you think that satisfactory answers were given to your questions during the training programme?	Yes [<input checked="" type="checkbox"/>]	No [<input type="checkbox"/>]	
Do you think that the background training manual is informative and useful enough?	Yes [<input checked="" type="checkbox"/>]	No [<input type="checkbox"/>]	
Do you think that the discussion on EE/RE will help you in your work?	Yes [<input checked="" type="checkbox"/>]	No [<input type="checkbox"/>]	
Suggestions & Recommendations for improvement:			
Name two learning, which from this programme you will be able to implement in your plant?			
Signature: <i>[Signature]</i>			
Name of participant: <i>Sachin D. Patil</i>			
Organization: <i>Inducto Therson</i>			
Mobile No: <i>9372852023</i>			
Email ID: <i>spatil@inductotherson.org.com</i>			

Organized by





Capacity building workshop

Energy efficiency improvements in compressed air and cooling water systems

Wednesday, 07 March 2018

Training Hall, Belgaum Foundry Cluster

Supported by:

GEF-UNIDO-BEE Project

Promoting Energy Efficiency and Renewable Energy in selected MSME clusters in India

Evaluation Sheet for Participants

Feedback Form for Participants			
Parameter	Feedback		
	Excellent	Good	Average
How would you rate the overall programme?	✓		
How would you rate overall arrangements?	✓		
How was the training schedule and agenda?		✓	
How was the industrial site visit?			
Do you think that adequate time was provided for each topic?	Yes [✓]	No []	
Do you think that satisfactory answers were given to your questions during the training programme?	Yes [✓]	No []	
Do you think that the background training manual is informative and useful enough?	Yes [✓]	No []	
Do you think that the discussion on EE/RE will help you in your work?	Yes [✓]	No []	
Suggestions & Recommendations for improvement:			
Name two learning, which from this programme you will be able to implement in your plant?			
Signature:			
Name of participant:	AMIT SATHAYE		
Organization:	Prakash Sales Agencies		
Mobile No:	9449053626		
Email ID:	psabym@gmail.com		

Organized by





Capacity building workshop

Energy efficiency improvements in compressed air and cooling water systems

Wednesday, 07 March 2018

Training Hall, Belgaum Foundry Cluster

Supported by:

GEF-UNIDO-BEE Project

Promoting Energy Efficiency and Renewable Energy in selected MSME clusters in India

Evaluation Sheet for Participants

Feedback Form for Participants			
Parameter	Feedback		
	Excellent	Good	Average
How would you rate the overall programme?	✓		
How would you rate overall arrangements?	✓		
How was the training schedule and agenda?	✓		
How was the industrial site visit?		✓	
Do you think that adequate time was provided for each topic?	Yes [✓]	No []	
Do you think that satisfactory answers were given to your questions during the training programme?	Yes [✓]	No []	
Do you think that the background training manual is informative and useful enough?	Yes [✓]	No []	
Do you think that the discussion on EE/RE will help you in your work?	Yes [✓]	No []	
Suggestions & Recommendations for improvement:			
Overall is Good			
Name two learning, which from this programme you will be able to implement in your plant?			
1) Compressor Exhaust system Improvement			
2) Inlet water flow detection			
3) Inlet Air into the Compressor monitoring			
4) AC, R, D system improvement			
Signature: <i>Chougala</i>			
Name of participant: <i>Ajit A. Chougala</i>			
Organization: <i>BIA Castings Pvt. Ltd.</i>			
Mobile No: <i>9964763950 / 9513395170</i>			
Email ID: <i>ajit.chougala@bigcastings.com</i>			

Organized by



Annexure 5: Copy of presentations



Energy efficiency improvement opportunities in induction furnace cooling water system

Capacity building workshop
Energy Efficiency and Renewable Energy Technologies
Wednesday, 7th March 2018
Belgaum

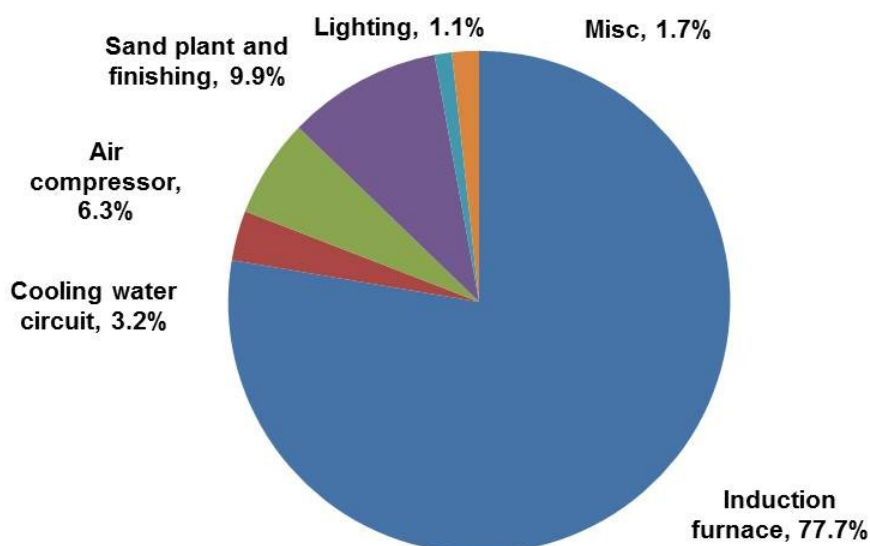

Pump and pumping system

Power consumption (kW)

- Usually lower than rated power
- Near to or higher than rated if re-winded



Flow rate (cu.m/hour)

- Most cases it was lower than design, few cases < 60% of design flow rate

Head (m)

- Most cases pressure gauges found not functioning

Optimizing piping design

- Water velocity ~ 1.8 – 2.0 m/s



3

Approach

➤ Design data

- ✓ Flow rate, m³/hour
- ✓ Design head, m
- ✓ Rated power, kW

➤ Performance assessment

- ✓ Estimation of hydraulic power
- ✓ Efficiency of pump



Approach



- Hydraulic power
- Overall system efficiency = Hydraulic power, kW / motor power, kW
- Pump efficiency, % = Overall efficiency / motor efficiency
- Operating point on the Pump system curve

Pumping system



Parameters to be measured/monitored

- Suction head and discharge head (Pressures), bar
- Pump motor power, kW
- Water flow, m³/hr
- Frequent check of impeller and motor bearings

Pumping system



□ Instruments needed for in house monitoring

- Ultrasonic flow meter
- Pressure gauges for discharge and suction pressures, bar
- Single phase power meter, kW



Selection and sizing – Before installation



Pump specification

- Flow rate, lpm (litres per minute)
- Head, m
- Power rating, hp / kW
- Pump-motor set efficiency, %
 - 34%, 37%, 40%, 47%, 59%

Piping

- To minimize friction loss
- Water velocity typical design 1.8 – 2.0 m/s
- Based on economics

Selection and sizing – Before installation



1. Each centrifugal pump has a BEP at which its operating efficiency is highest and its radial bearing loads are lowest.
2. At or near its BEP, a pump operates most cost effectively in terms of both energy efficiency and maintenance
3. Selecting a pump with a BEP that is close to the system's normal operating range can result in significant operating cost savings.

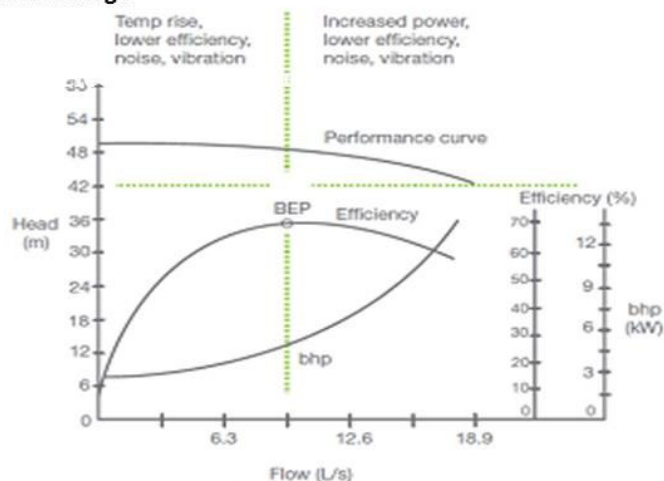
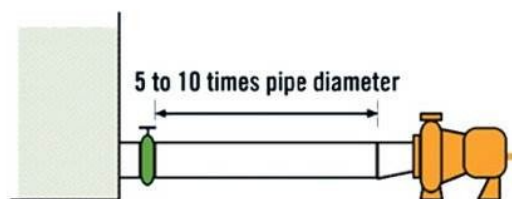

Figure 3.1.1 Pump operating point

Selection and Pipe sizing – Before installation



1. KEEP SUCTION PIPING AS SHORT AS POSSIBLE



2. PIPE DIAMETER ON SUCTION SIDE SHOULD BE EQUAL OR ONE SIZE LARGER THAN PUMP INLET

Selection and Pipe sizing – Before installation

3. ELIMINATE ELBOWS MOUNTED ON OR CLOSE TO THE INLET NOZZLE OF THE PUMP (I.E TO AVOID BENDS IN SUCTION PIPES TO ELIMINATE PRESSURE DROP)



Pumping System



Pressure gauge for pressure indication

Selection and Foot valve – Before installation

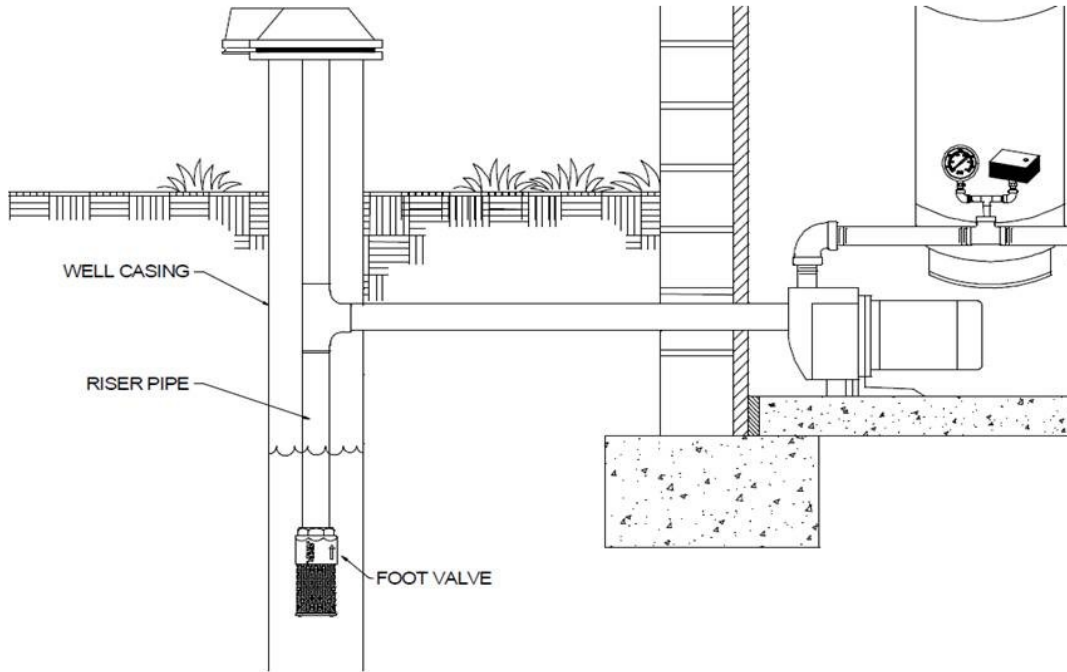
Selection and Foot valve – Before installation



Foot Valve Location

Foot Valve Location	Recommended Foot Valve Installation:
Max. 25 feet or less below pump suction inlet	Install Foot Valve in a vertical position for best and most efficient operation.



Pumping System



- Eliminate unnecessary uses

Energy Efficiency Measure	Typical % improvement in energy efficiency over current Pump system efficiency practice		
	% Improvement over LOW eff. base case	% Improvement over MED eff. base case	% Improvement over HIGH eff. base case
Use pressure switches to shut down unnecessary pumps	10.0%	5.0%	2.0%
Isolate flow paths to nonessential or non-operating equipment	20.0%	10.0%	5.0%

Pumping system



- Upgrade System Maintenance

Energy Efficiency Measure	Typical % improvement in energy efficiency over current Pump system efficiency practice		
	% Improvement over LOW eff. base case	% Improvement over MED eff. base case	% Improvement over HIGH eff. base case
Fix Leaks, damaged seals, and packing	3.5%	2.5%	1.0%
Remove scale from components such as heat exchangers and strainers	10.0%	5.0%	2.0%
Remove sediment/scale buildup from piping	12.0%	7.0%	3.0%

Pumping system

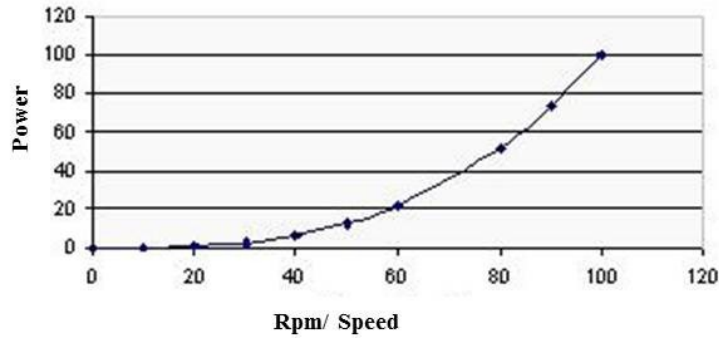
✓ For variable loading , like in case of pump with a variable load can reduce it flow by lowering its RPM and generate substantial saving

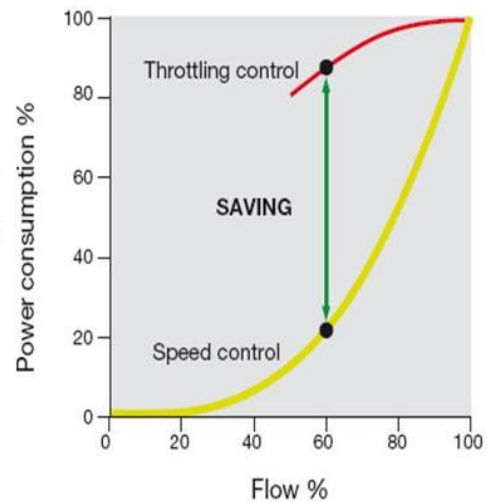

Pumping System



- Meet variable flow rate requirement w/o throttling or bypass

Energy Efficiency Measure	Typical % improvement in energy efficiency over current Pump system efficiency practice		
	% Improvement over LOW eff. base case	% Improvement over MED eff. base case	% Improvement over HIGH eff. base case
Install variable speed drive	25.0%	15.0%	10.0%
Replace pump with more energy efficient type	25.0%	15.0%	5.0%
Replace motor with more energy efficient type	5.0%	3.0%	1.0%
Initiate predictive maintenance program	12.0%	9.0%	3.0%

Pumping System



Common Problem	Potential Measures to Improve Efficiency
Unnecessary demand on pumping system	Reduce demand on system
Oversized pumps	Select pump that operates near to BEP Change impeller Trim impeller Fit multiple-speed pump Use multiple-pump arrangements Fit lower speed pump/ motor
Pump wear	Pump maintenance
Less efficient impeller	Change impeller
Inefficient pump throttling controls	As for oversized pumps Fit adjustable or variable-speed drive
Inefficient piping configuration	Change piping inefficiencies
Oversized motor	Change motor
Inefficient motor	Change to high-efficiency motor
Lack of monitoring and/ or documentation	Install monitoring and conduct survey

Pumping System



ECM: Replacement of monoblock pump with EE monoblock multistage pump for coil cooling

Recommended Pump Specification	Units	Coil cooling pump for Furnace
Flow rate	m ³ /hour	14.4
Differential Head	m	40.0
Efficiency	%	51.1%
Power proposed pump	kW	3.07
Power saving	kW	1.43
Operating period	hour	4,800
Annual Energy saving	kWh/year	6,856
Cost saving		
Annual Monetary Saving	Rs lakh / year	0.42
Investment	Rs lakh	0.55
Simple Payback Period	years	1.3

Pumping System



High efficiency Pump

Flow characteristic is improved and power consumption reduced

21

Pumping System



17,280
kWh/year

0.45 Years
Simple
Payback
Period

17.0
tCO₂/
year

Replacement of old single stage pump with new EE horizontal multistage pump





Cooling Tower



Drift eliminators: These capture water droplets entrapped in the air stream that otherwise would be lost to the atmosphere.

Air inlet: This is the point of entry for the air entering a tower. The inlet may take up an entire side of a tower—cross flow design— or be located low on the side or the bottom of counter flow designs.

Louvers: Generally, cross-flow towers have inlet louvers. The purpose of louvers is to equalize air flow into the fill and retain the water within the tower. Many counter flow tower designs do not require louvers.

Nozzles: These provide the water sprays to wet the fill. Uniform water distribution at the top of the fill is essential to achieve proper wetting of the entire fill surface. Nozzles can either be fixed in place and have either round or square spray patterns or can be part of a rotating assembly as found in some circular cross-section towers.

Fans: Both axial (propeller type) and centrifugal fans are used in towers. Generally, propeller fans are used in induced draft towers and both propeller and centrifugal fans are found in forced draft towers. Depending upon their size, propeller fans can either be fixed or variable pitch.

A fan having non-automatic adjustable pitch blades permits the same fan to be used over a wide range of kW with the fan adjusted to deliver the desired air flow at the lowest power consumption.

Automatic variable pitch blades can vary air flow in response to changing load conditions.

Cooling Tower

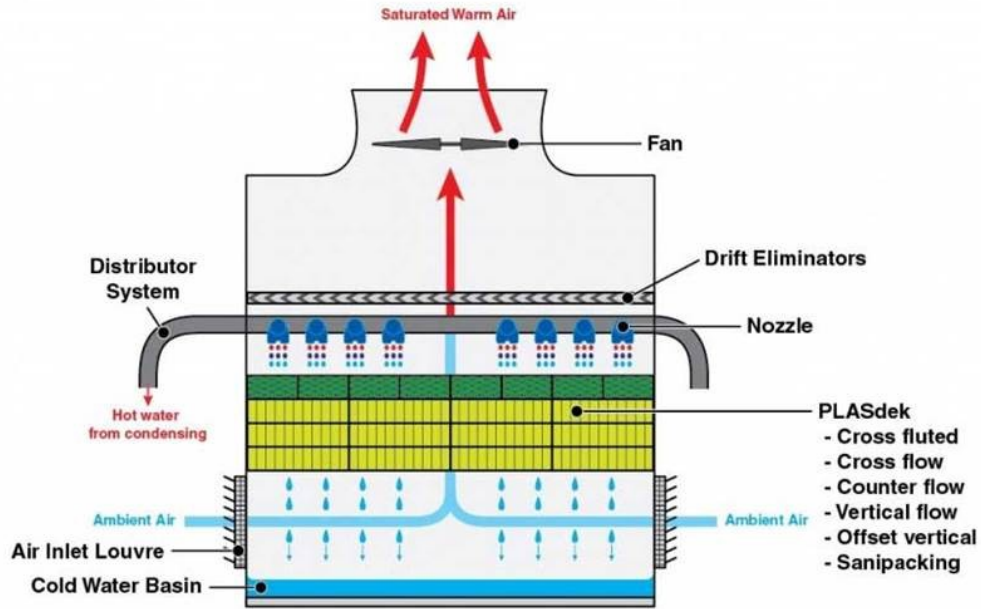

Counterflow Tower

Cooling Tower

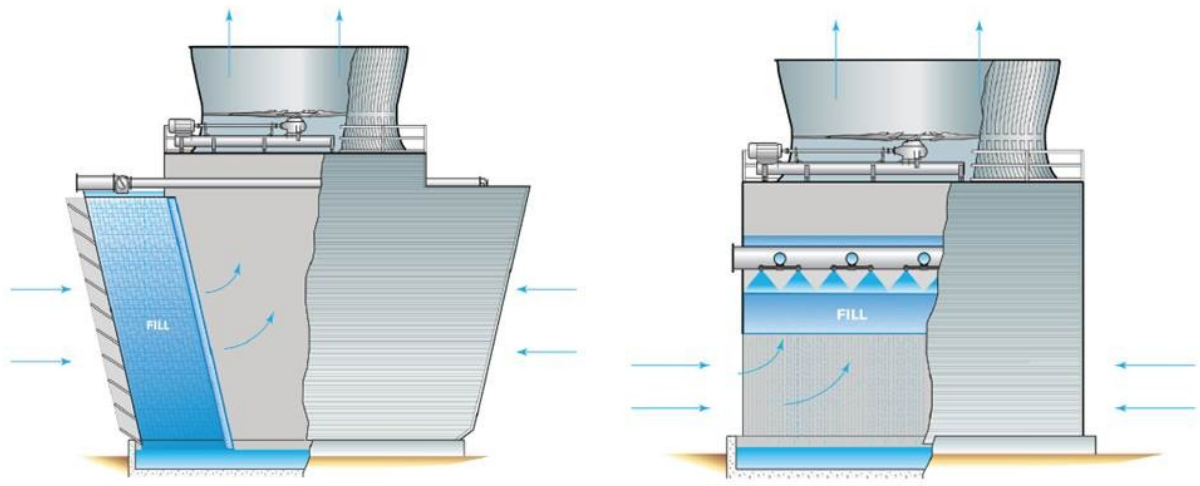

Crossflow Design

Counterflow Design

Cooling Tower

Operating Parameters of Cooling tower

S No	Parameter
1	Ambient dry bulb temperature (°C)
2	Ambient wetbulb temperature (°C)
3	Average Cooling water inlet temperature (°C)
4	Average Cooling water outlet temperature (°C)
5	Average Cooling duty water flow rate (m ³ /hour)

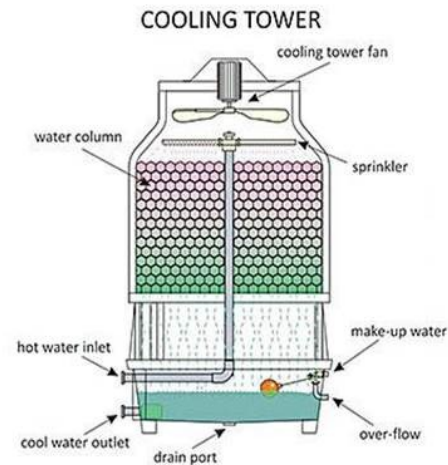

27

Cooling Tower

Performance assessment of cooling tower

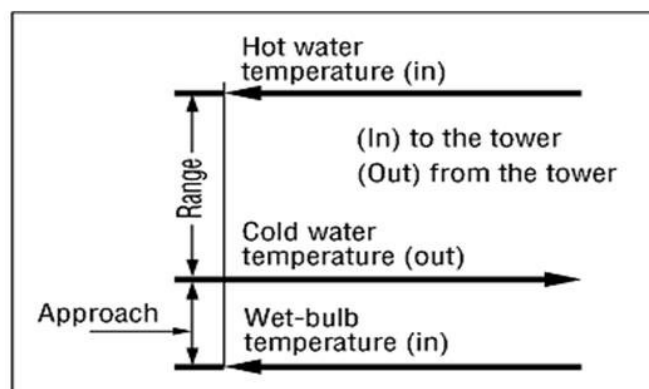

28

Cooling Tower



Range = Entering cooling water temperature(return from process) – Leaving water temperature (supply to process)

High range means good performance of cooling tower

Approach = Leaving cooling water temperature – Ambient wet bulb temperature

Low Approach means good performance of cooling tower

Effectiveness = $\text{Range} / (\text{Range} + \text{Approach})$

High effectiveness means good performance of cooling tower

Heat rejected in TR = $(\text{Mass flow rate} \times \text{specific heat} \times \text{range}) / 3024$

High cooling capacity means good performance of cooling tower

29

Cooling Tower



Energy efficiency opportunities in cooling tower

1. Selecting a cooling tower (Approach closer to WBT)
2. Fills
3. Pump and water distribution system
4. Fan and Motors

30

Cooling Tower



1. The fill is merely a media by which more water surface is caused to be exposed to the air (increasing the rate of heat transfer), and which increases the time of air-water contact by retarding the progress of the water (increasing the amount of heat transfer).
2. Splash-fill causes the flowing water to cascade through successive elevations of parallel “splash bars.” Equally important is the increased time of air-water contact brought about by repeated interruption of the water’s flow progress.
3. Film-fill has gained prominence in the cooling tower industry because of its ability to expose greater water surface within a given packed volume.

31

Cooling Tower



Energy Efficiency opportunities in cooling tower

Selecting a cooling tower

Depending on relationship between Approach and wet bulb temperature.
Use drift eliminators to minimise drift loss

Fills

	Splash Fill	Film Fill	Low Clog Film Fill
Possible L/G Ratio	1.1 – 1.5	1.5 – 2.0	1.4 – 1.8
Effective Heat Exchange Area	30 – 45 m ² /m ³	150 m ² /m ³	85 – 100 m ² /m ³
Fill Height Required	5 – 10 m	1.2 – 1.5 m	1.5 – 1.8 m
Pumping Head Requirement	9 – 12 m	5 – 8 m	6 – 9 m
Quantity of Air Required	High	Much low	Low

32

Cooling Tower

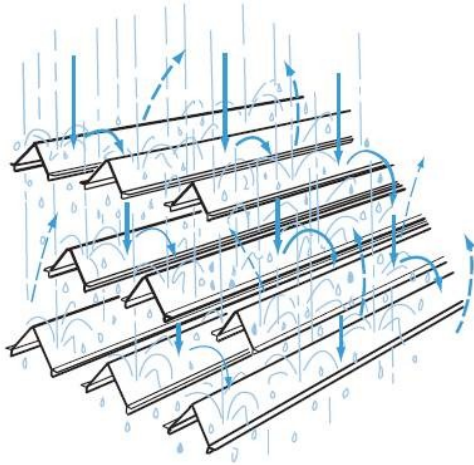

Splash Fill

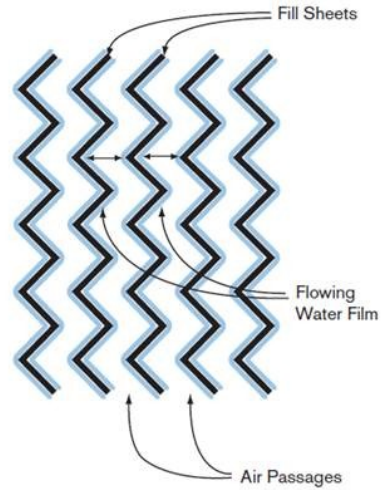

Film Fill

33

Cooling Tower



Splash Film Installed



Film Fill Installed

34

Cooling Tower

Energy Efficiency opportunities in cooling tower

Fans and Motors

1. Fan must overcome system resistance, pressure loss : impacts electricity use
2. Fan efficiency depends on blade profile
Replace metallic blades with FRP blades (15-20% energy saving potential)
3. Use blade with aerodynamic profile (Fan efficiency 85-92%)
4. Use IE3 premium standard motors for cooling tower fan motors (3-6% energy saving potential)

35

Cooling Tower

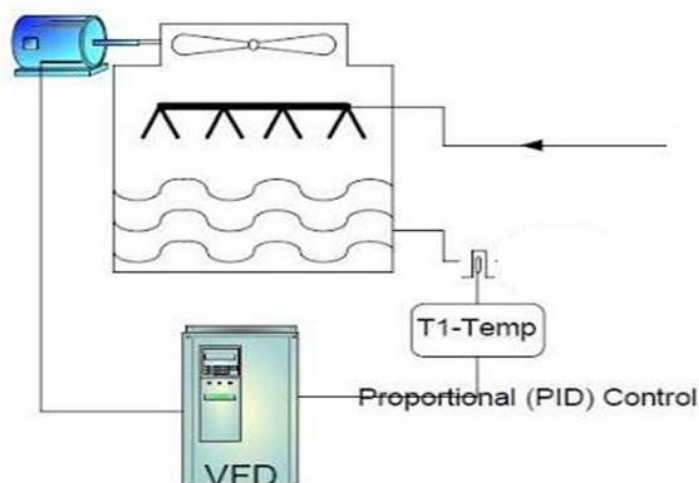

Temperature control automation for cooling tower

36

Cooling Tower



Induced Draft Cooling Tower



Forced Draft Cooling Tower

37

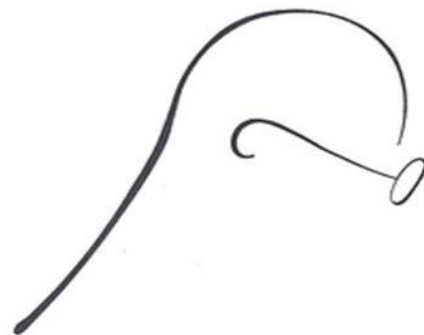

Be the change you want to see in the world

Vivek Sharma
Associate Fellow
+91 9850366248
Vivek.sharma@teri.res.in



Capacity building workshop Energy efficiency improvements in compressed air systems

Wednesday 7th March 2018

Belgaum

Nilesh Shedge, TERI



The Energy and Resources Institute



Contents

- » Understanding of air compressors
- » Understanding of compressed air **system**
- » Energy consumption & cost effectiveness
- » Check points in compressed air system
- » Energy savings best practices
 - » Notes
 - » Examples
 - » Dos & Donts
- » Select case studies

Introduction

Reciprocating air compressor



Compressed air systems are quite inefficient and only 10-30% of energy reaches the point of end-use

Source: Compressed air system, Bureau of Energy Efficiency

Type of air compressors

Screw air compressor



Components of compressed air system

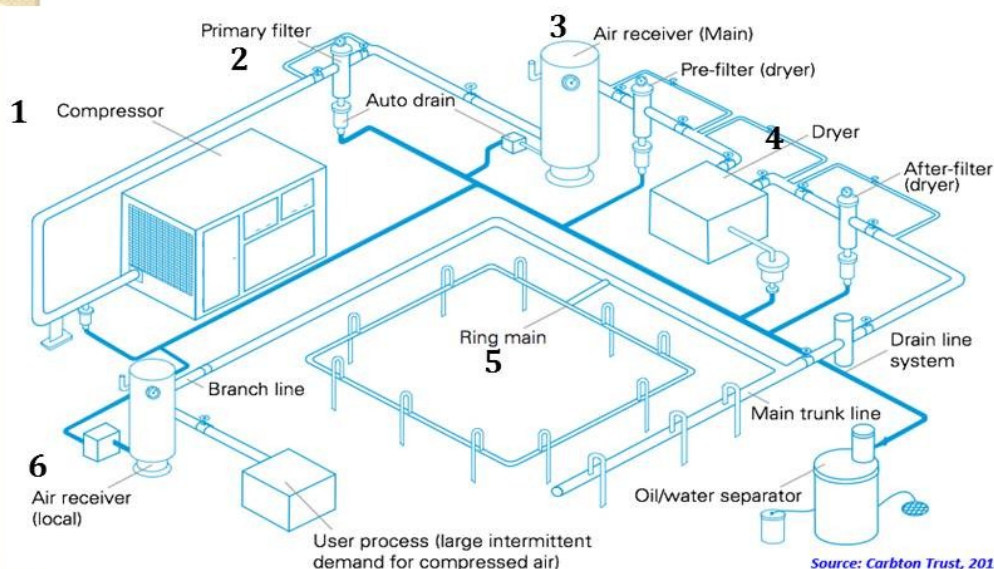

Source: Carleton Trust, 2012.

Summarizing understanding of compressed air system

- Air compressor – converts atm air into pressurized air
- Receiver tanks – used for storage
- Dryers – used for removing water vapours
- Filters – used for cleaning or removing any particles
- Pipes – used for transporting
- Valves – used for control
- Pressure gauges – used for monitoring pressure levels
- Flow meters – used for monitoring volume

What is Energy consumption of air compressor?

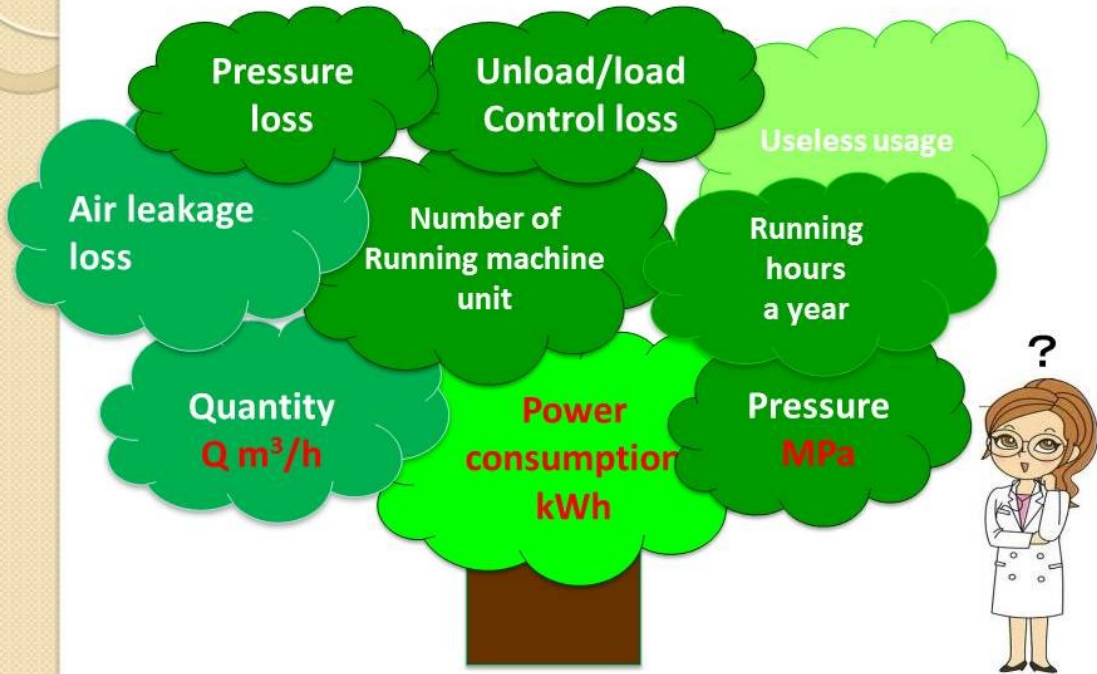

Life cycle costing

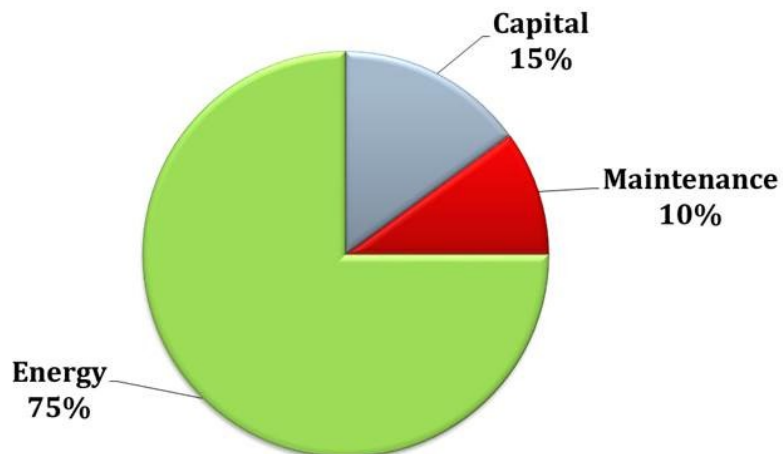

By proper management energy saving to the tune of 10 - 50% can be achieved in a compressed air system

Energy savings best practices

- » Pressure settings for reciprocating, screw type (energy savings 8 to 16 %)
- » Cool & fresh air at suction (energy savings 3%)
- » Air leakages reduction (energy savings 10 to 40 %)
- » Effective use of compressed air (energy savings 3 to 7%)
- » Pipe sizing & design (savings 7 to 20 %)
- » Type of air compressor and overall condition (savings 7 to 15 %)
- » Inverter type (VFD driven) air compressor (savings 11 to 43 %)

Pressure setting optimization:

Characteristics of Air Compressor (positive displacement compressor)

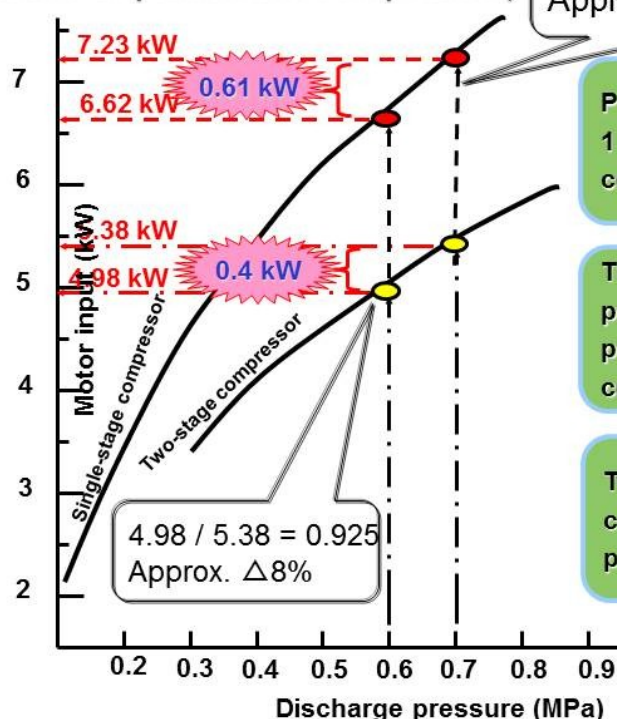

6.62 / 7.23 = 0.915
Approx. $\Delta 8\%$

Power consumption when 1 m³/min of air is compressed

The lower the discharge pressure, the lower the power required for compression.

Two-stage compressors can compress air with lower power.

Air compressor location

- Proper Ventilation
- Dust free location
- Platform for Machine



Presentation by Chetankumar Sangole, TERI

- Proper Ducts for machines
- Air filters on windows



Notes for Duct Installation Work

- Provide a suction port low on the wall on the opposite side of the discharge port.
- Be careful that the discharge port and suction port are NOT placed on the same side.

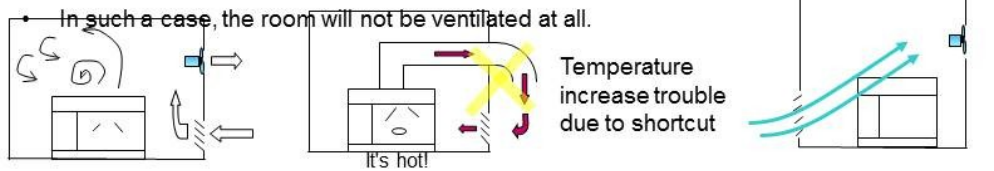

Air will not be discharged properly, leading to a failure.

The same rule applies when air is discharged through a duct using a blower or ventilator. Even with forced exhaust, if ducts are combined into a single duct, balance will not be maintained. Overflowing discharge air may be taken into the neighbor machine.

Be sure to provide a separate discharge duct for each compressor. Do not share a discharge duct for 2 or 3 compressors.

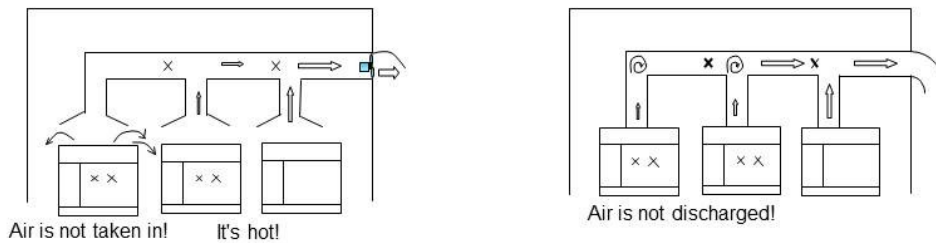

Improved exhaust system



FAN

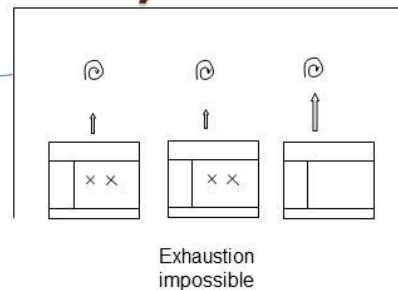

- It is an open room; therefore, the existing exhaust fan does not demonstrate any exhaust capacity.
- If a screw type is used, please install an exhaust air duct as shown in the figure below.
- Increase in the compressor room temperature will result in the degraded compressor performance
- For example, a temperature increase of 3 deg. C. will degrade the compressor's performance by 1%.
- If the suction pressure drops; the efficiency of the compressor will also be reduced.

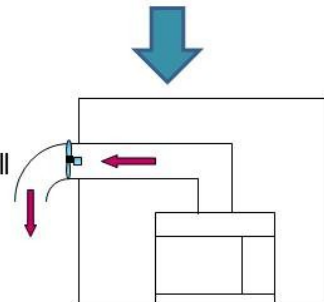

Air leak points (select cases)

Leakage cases

10-20% of leakage exists in a plant on average



point ; valves
1 7 . 4 L/min



point ; air gun
4 9 . 2 L/min

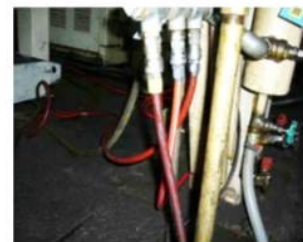

point ; hoses
5 9 . 4 L/min



point ; hose joint
5 9 . 4 L/min



point ; regulator
7 1 . 7 L/min



point ; coupler
2 7 . 7 L/min

Example of effective air blow

How much effect?

Air consumption is big for air blow when using direct cutting edge of long pipe

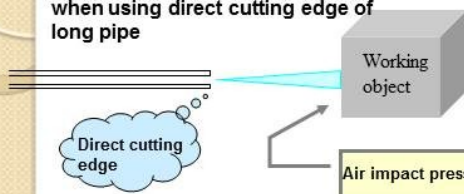

Pressure loss big = Air consumption big

Air blow is much effective when using air nozzle attached just before cutting edge

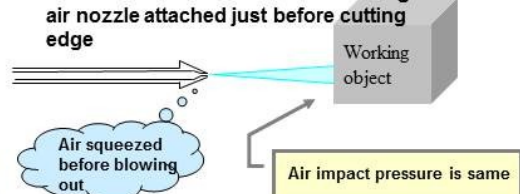

Pressure loss small = Air consumption small



Brow gun

When air blow pressure made high

Even if pressure reduction is made, air blow contacting pressure is the same as before and after.



Shapes of nozzle promote air blow different

Pressure loss

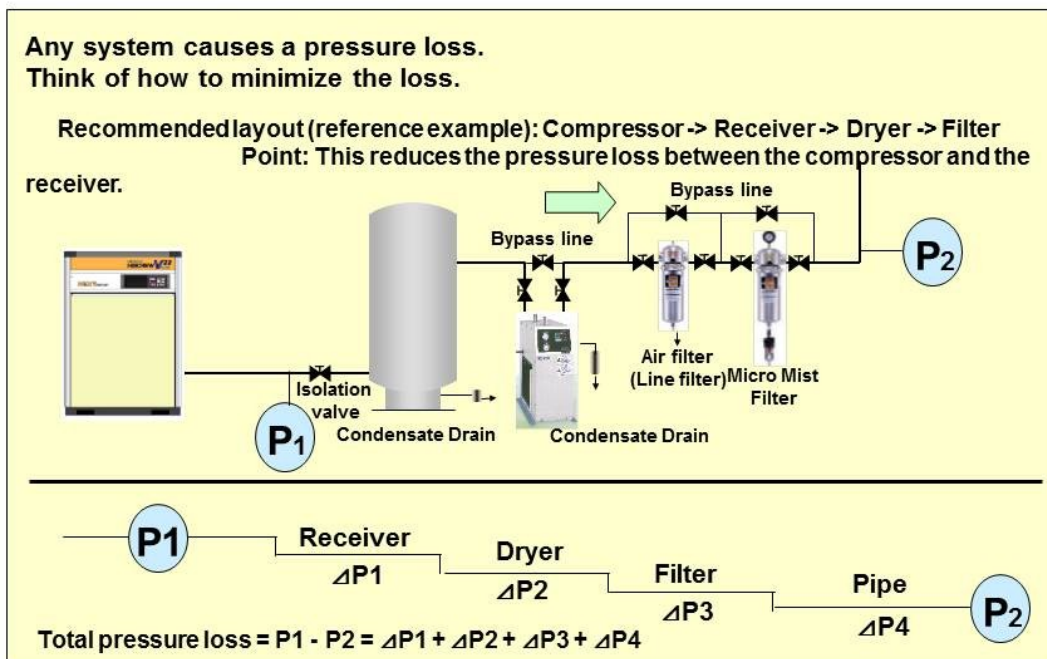

To achieve a higher rate of **energy saving**, select a pipe having a **diameter one size larger than the compressor's discharge pipe diameter**. Also, select air dryers and filters having a **capacity one size larger**.

Contents of Improvement Measures - Examination of Piping Work



- Example of pipes having many valves or bends generates resistance, causing pressure loss.
- Change the type of the valves (to the one with low resistance) or reduce bends as much as possible



- A pipe narrowed immediately after the air dryer. Generates resistance, causing pressure loss.
- A riser pipe. Causes a backward flow of condensate, leading to an increasing number of mechanical troubles.

Examples of problematic piping



- Drain trap attached just behind the compressor.
- Clogging of the pipe may be caused.
- Also, it increases the resistance at the immediate back of the compressor, which not only causes energy loss but also makes control difficult.



- Rust of receiver tank and internal corrosion.
- Internal resistance increases.
- It is recommended that a receiver tank with internal treatment with epoxy or similar be selected.



- Rubber hose connected from the compressor to the discharge pipe.
- It causes a large internal resistance and is inappropriate in terms of energy saving.
- Rubber hoses generate resistance higher by 20% or more than steel pipes and are not inappropriate.

Examples of recommended piping



Provide a drain plug for a riser pipe.



Recommended collecting pipe



Riser pipe installed from above



Large-bore pipe and receiver tank with adequate capacity

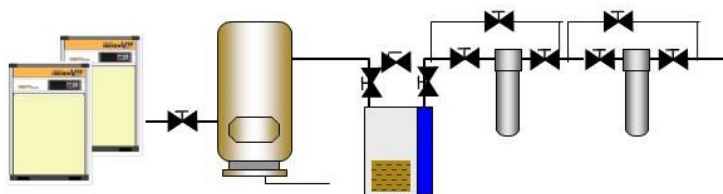

Recommended equipment and pipe flow

Drain valves



Solenoid control drain valve



Automatic Drain Valve (mechanical type)

Notes for Piping Work

1. Be sure to provide a drain connection for a riser pipe. Installation to a collecting pipe must be made from above to prevent backflow. (Similarly, branch pipes must be installed from above.)
2. For a collecting pipe, give an inclination (1/100) from the upstream to the downstream. Attach a drain plug at the end of each pipe.

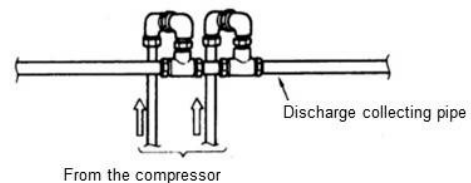
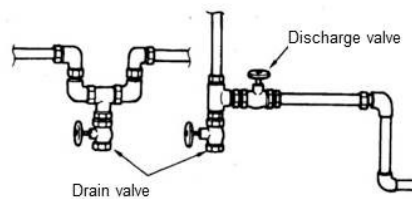

3. Buried piping makes it difficult not only to detect air leakage but also to repair. Therefore above-ground piping must be adopted. If buried piping is inevitable, install the pipes in a pit.

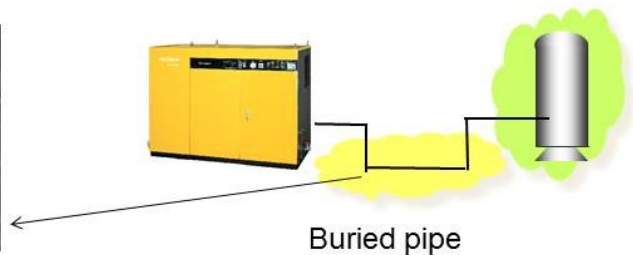

Changing air velocity through internal pipe . . . loop piping

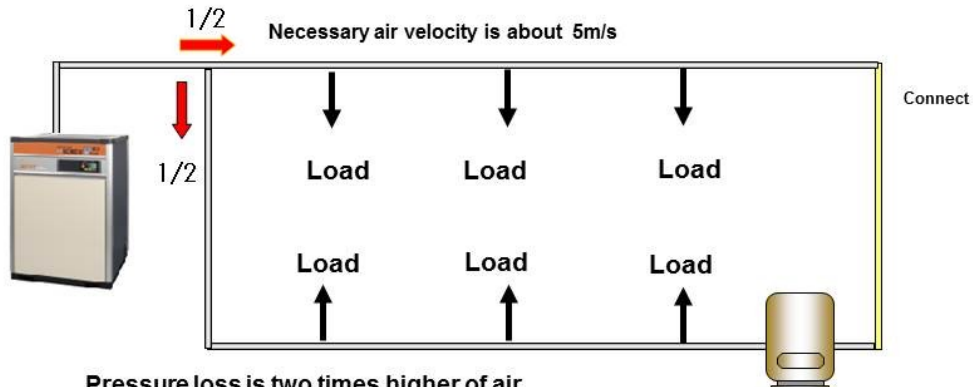

Pressure loss is two times higher of air velocity in proportion

Pressure loss is minimized to one quarter, only to make loop piping!

How much improvement can be made with loop piping?

Pressure loss become one quarter, only to make loop piping if there is imbalance among load.

Select dos & don'ts – air compressor area

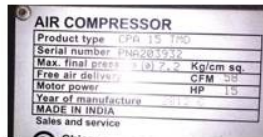

Example of Energy-Savings 【Improvement of Air Compressor】

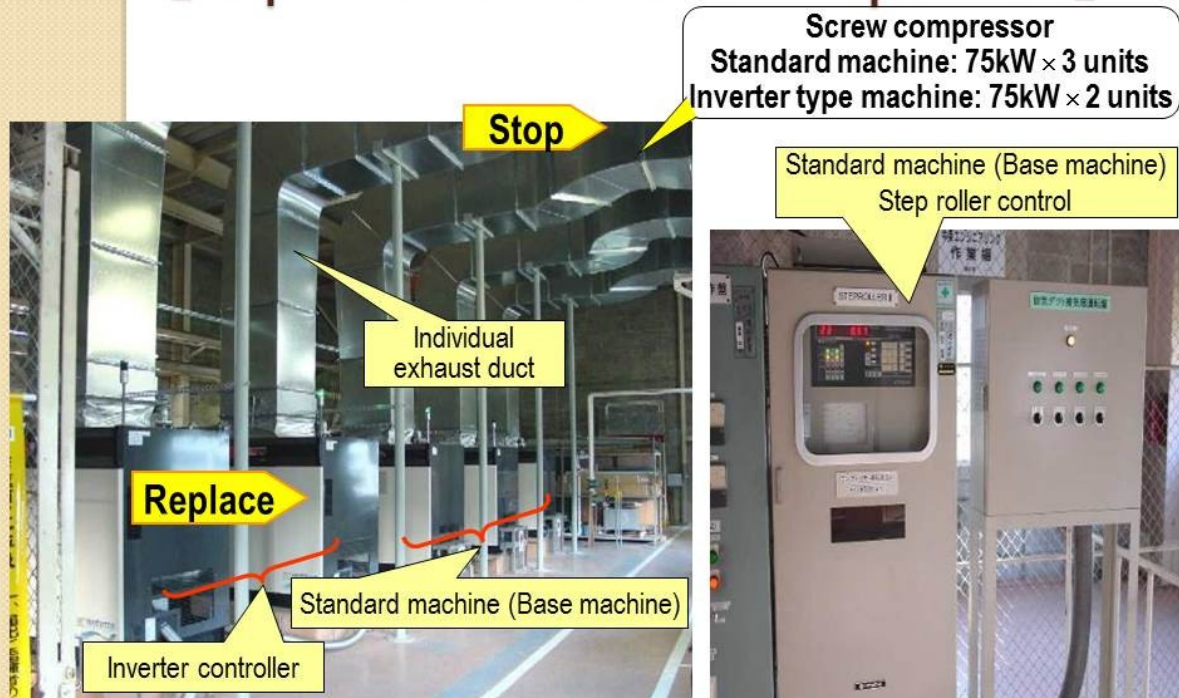

Which Is More Energy Saving - Collective or Independent?

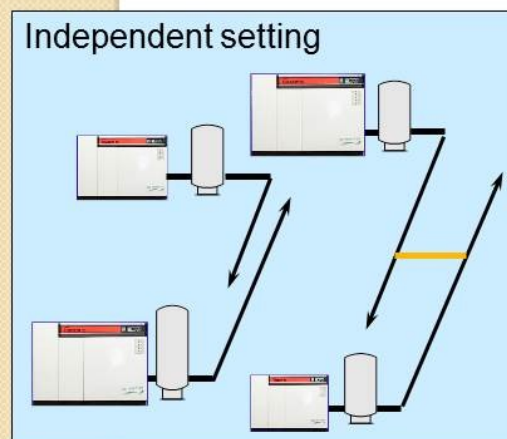
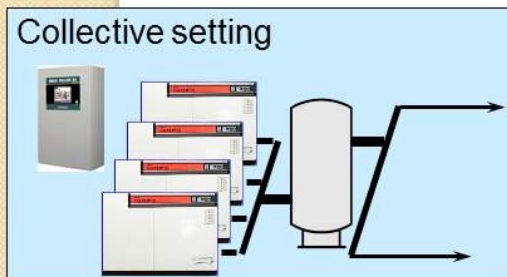

Setting Type	Collective	Independent
Daily Maintenance	Easy	Need to assign staff for each line
Regular maintenance	Easy	Need maintenance in each line
Pressure flexibility	Need to operate with the highest pressure equipment (Some loss)	Able to apply appropriate pressure for each piece of equipment (Min. loss)
Pressure loss	Some Piping tends to be long	Small Piping can be short Adjustment can be made in each line
Air leak	Affects whole air supply system	Affects only line with the leakage
Multi-unit Control	Available	Unavailable

Energy saving can be made using inverter compressor for both collective & independent settings.

1. Collective setting: Inverter compressor absorbs load fluctuation
2. Independent setting: Easy to accomplish energy saving

Air filters cleaning



Presentation by Chetankumar Sangole, TERI



Presentation by Chetankumar Sangole, TERI

Exhaust Duct for Screw Air Compressors



Air receiver size

100CFM=1000litres



Air compressor

Base case

Before Air Manager	Total run hr/day	Off time hrs	Total time hr/day	Energy consumption (kWh/day)
Screw compressor (45 kW)	16	0.7	16.7	764
Screw compressor (30 kW)	7	7.7	14.7	154
Screw compressor (22 kW)	14	7	21	302
		Total		1220



Implementation

After Air Manager	Total Run hrs	Off time hrs	Total Time hrs	Per day energy consumption, kWh
Screw compressor (45 kW)	10	13.5	23.5	495
Screw compressor (30 kW)	11	12.6	23.6	301
Screw compressor (22 kW)	17	6	23	331
		Total		1127



Estimated energy saving: 27685 kWh/annum

Implementation- Case Studies

81,776
kWh/year

1.2 Years
Simple
Payback
Period

Rs. 6
lakh/y
ear

Replacement of existing screw air compressor with new EE screw air compressor with VFD and Permanent Magnet Synchronous (PMSN) motor



Implementation- Case Studies

113,002
kWh/year

1.5 Years
Simple
Payback
Period

Rs. 8
lakh/y
ear

Replacement of existing screw air compressor with new EE screw air compressor with VFD and Permanent Magnet Synchronous (PMSN) motor



Implementation- Case Studies

38,965
kWh/year

1.4 Years
Simple
Payback
Period

38.2
tCO₂/
year

Replacement of existing reciprocating air compressor with new energy efficient VFD based screw air compressor



Implementation- Case Studies

9,851
kWh/year

Immediate
Payback

9.6
tCO₂/
year

Arresting the air leakages in the compressed air distribution network in the plant (use of crimped hose joints)

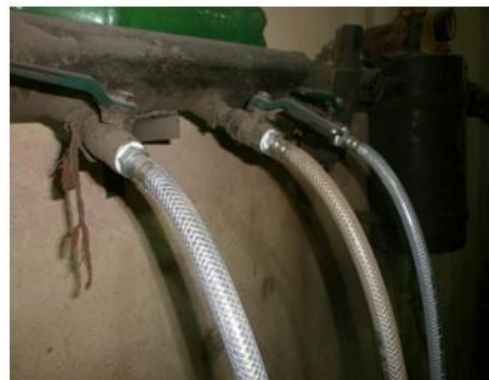

Thank you...!!!

The Energy and Resources Institute

Creating Innovative Solutions for a Sustainable Future

www.sameeksha.org

For any information, please contact

Nilesh Shedge – 9978601047
(nilesh.shedge@teri.res.in/nil.shedge@gmail.com)